

HUMBOLDT COUNTY BUILDING DEPARTMENT
CITY OF WINNEMUCCA BUILDING DEPARTMENT

*SINGLE FAMILY RESIDENTIAL
UNCOVERED DECK*

Complete this Building Guide by filling in the blanks on page 4 and indicating construction details used.

Provide Site Plan showing dimensions of your project or addition and its relationship to existing buildings or structures on the property and the distance to existing property lines.



For decks up to 14' in height measured to the underside of the beam. Decks over 14' high will need to be engineered.

A permit is not required for decks that are constructed with a walking surface that is less than 30" above grade. The following are the minimum **PLAN** requirements for decks that require a permit.

1. **Site plan.** Indicate the location of the deck, distance to other buildings, and distances to property lines (contact the Planning Dept. at 623-6392 for setback requirements).
2. **Dimensions.** Show: Width, Length, Height (measure from grade to top of walking surface).
3. **Foundations**
 - A. Min. 18"x18"x24" footings or 22" diameter x 24" deep sonatube
 - B. Specify type of post base
4. **Posts**
 - A. Post shall be pressure treated if in contact with the earth or concrete; or less than 8" above exposed ground. Pressure treated wood cuts to be field treated.
 - B. Size of posts (see table)
 - C. Specify distance between posts
5. **Deck Beams** (see table)
 - A. Specify girder size on the plans
 - B. Specify positive connection between posts and beams
6. **Floor Joists** (see table)
 - A. Size, spacing and span of floor joist on the plan
7. **Ledgers** (see attached table) Ledger may not be installed over siding, stucco or manufactured home wall. It must be fastened directly to the rim joist, stud or sheathing (i.e. remove stucco and siding behind the ledger). For manufactured home installation the ledger shall be installed directly to the foundation or must be free standing.
 - A. Ledger size (min. 2x8 and shall be pressure treated)
 - B. Size of bolts
 - C. Spacing of bolts
 - D. Hold down tension device (required in condition shown in Figure 507.2.3)
8. **Stair** – see handout. Full compliance is required.
9. **Guardrail** requirements (any portion of the deck over 30" above grade). Min. height of the guardrail is 36". Maximum spacing between intermediate rails is 4".

Provide a site plan showing the dimensions of your deck and its relationship to existing buildings or structure on the property and the distance to property lines

On site plan indicate details such as post location and spacing, joist and beam spans, and any other pertinent information.

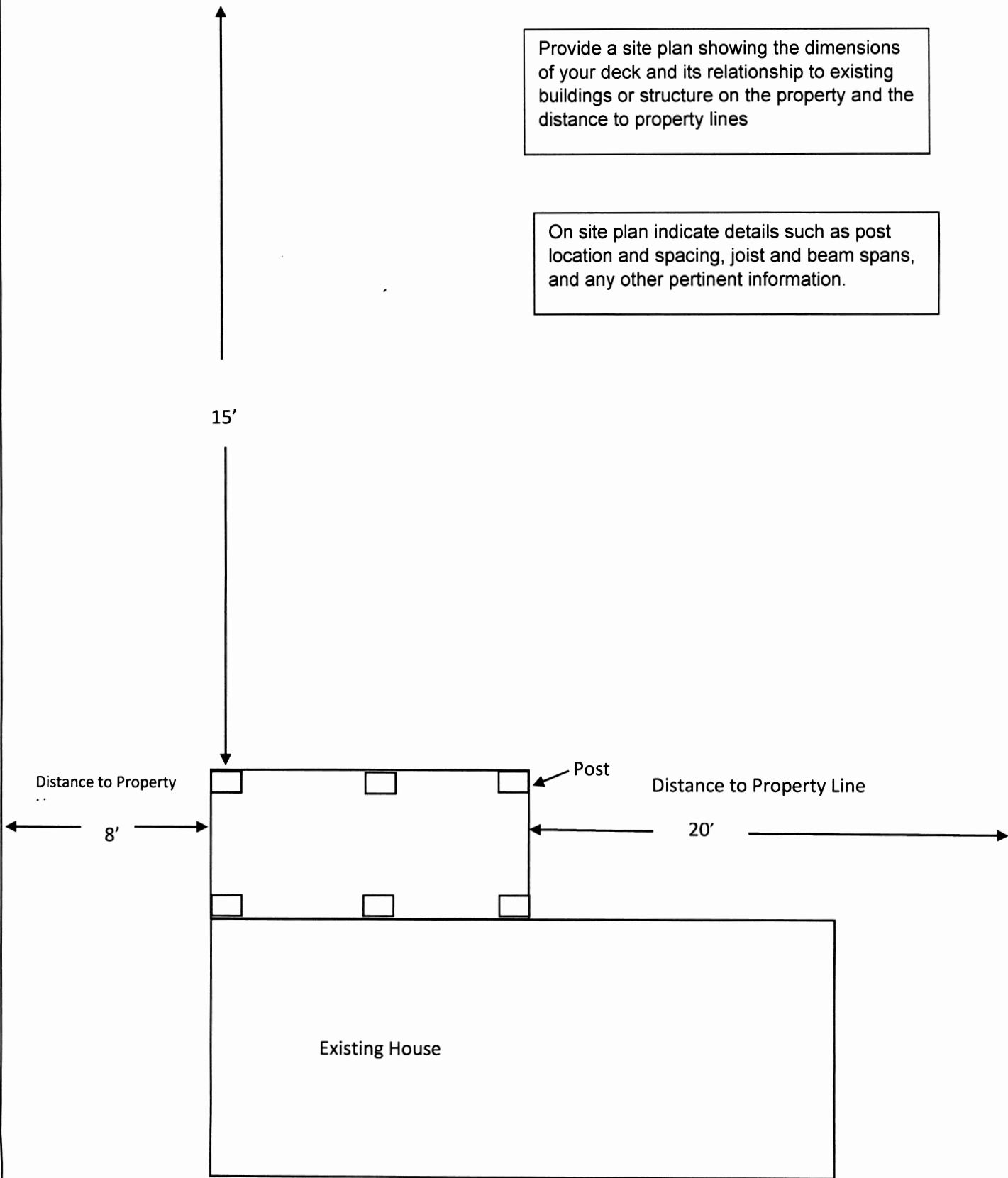

Single Family Residential Uncovered Decks and Porches

Directions

1. Fill in the blanks. Please print legibly.
2. Indicate in the check box which detail from page 5 will be used

Address: _____

Size and Amount of Lags
(example: Two 1/2"x 4 1/2" lags @ 16" O.C.)

Type of decking _____ x _____ - _____
(example: 1 x 4 or 2 x 6 - Trex)

2x _____ joists spaced _____" apart
(example: 2 x 10" spaced 24" apart)

() _____ x _____ beam
(example: (2) 2 x 10 - see detail B)

2x _____ rim joist
(example: 2 x 10 - see Alternate B1 & B2)

_____ x _____ posts spaced _____ apart
(example: 4 x 4 posts spaced 8' apart)

Span _____
(example: 13' - 4")

Type of siding (existing) _____

Deck Section

Existing bldg.

Approved flashing required

36" high guard with balusters spaced so that a 4 inch diameter sphere cannot pass through

Beam splices to occur over posts with 1 1/2" bearing

Attach decking with non corrosive fasteners

6 Ft. 8 in. min. (see note)

Finished grade

Note: Emergency escape windows are allowed to be installed under decks and porches provided the location of the deck allows the emergency escape window to be fully opened and provides a path not less than 36" in height to a yard or court. 6'8" required for walk out basements or patios.

Check one

Detail B

Alternate Detail B1

Alternate Detail B2

(see page 5)

Note: A plot plan (plan view) showing the dimensions of your project or additions and its relationships to existing buildings or structures on the property must be included. In addition to project dimensions, your plot plan must also show other details such as post locations and spacing, joist and beam spans, and any other pertinent information not shown on the section drawing.

Single Family Residential Uncovered Decks and Porches

Detail A

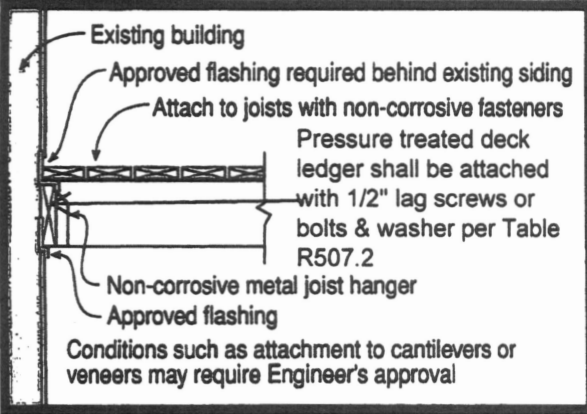

Detail B

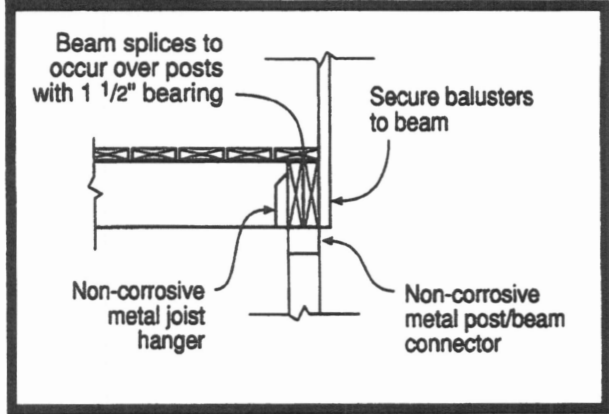

Alternate Detail B1

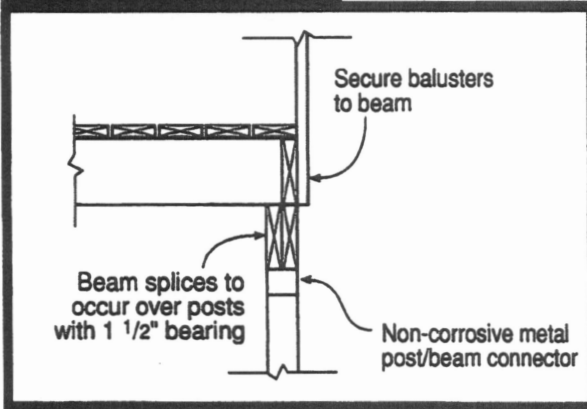

Alternate Detail B2

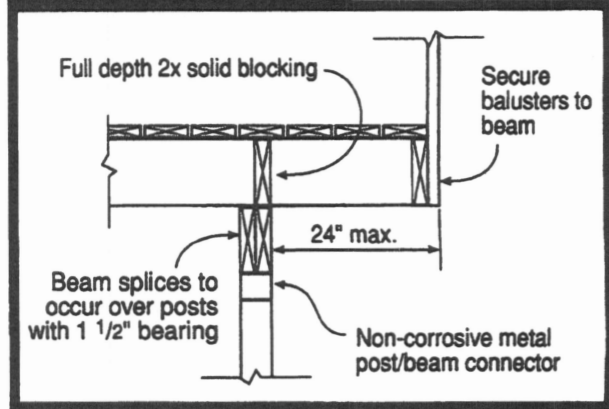

Detail C

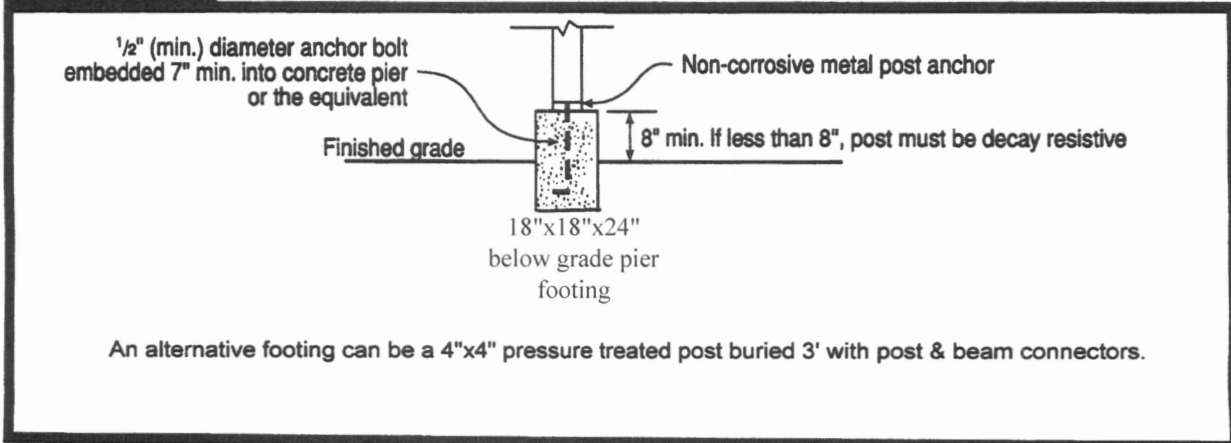

Single Family Residential Uncovered Decks and Porches

Stair & Handrail Specifications

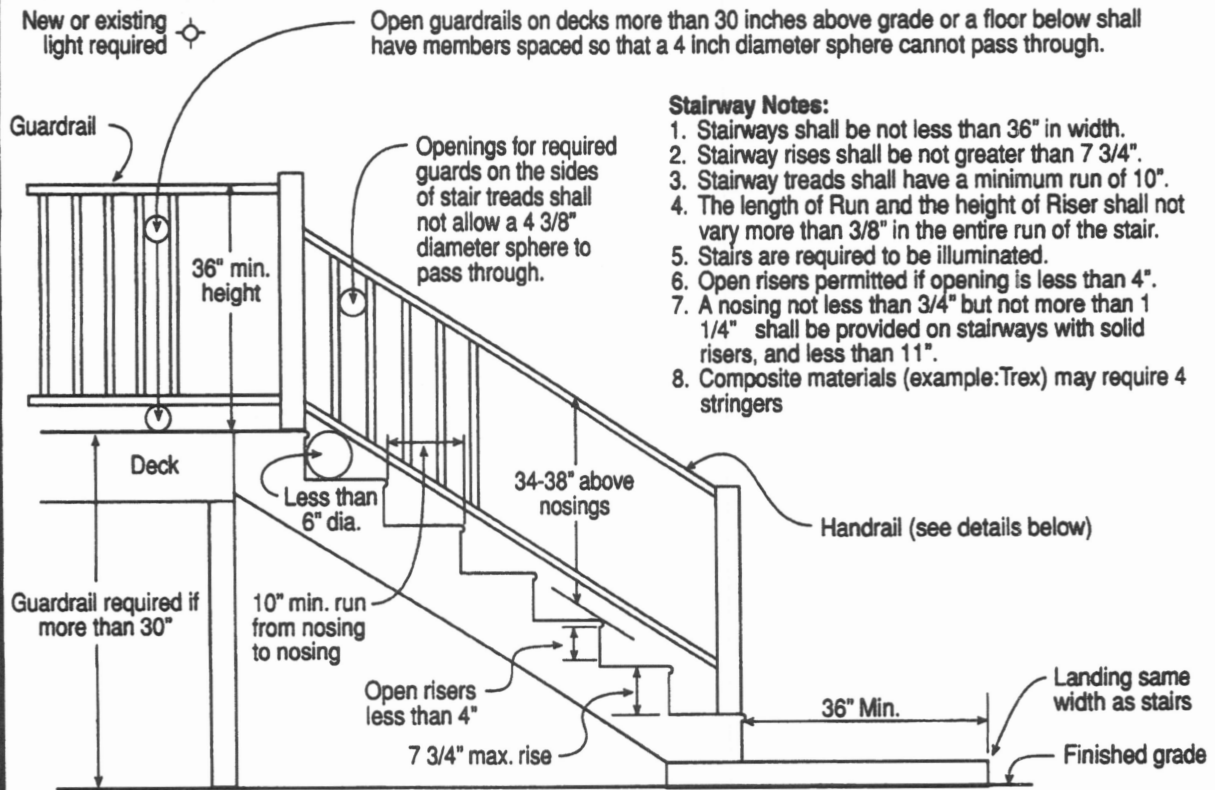

Stairway Notes:

1. Stairways shall be not less than 36" in width.
2. Stairway rises shall be not greater than 7 3/4".
3. Stairway treads shall have a minimum run of 10".
4. The length of Run and the height of Riser shall not vary more than 3/8" in the entire run of the stair.
5. Stairs are required to be illuminated.
6. Open risers permitted if opening is less than 4".
7. A nosing not less than 3/4" but not more than 1 1/4" shall be provided on stairways with solid risers, and less than 11".
8. Composite materials (example: Trex) may require 4 stringers

Handrail Notes:

1. Handrails shall be continuous on at least one side of stairs with 4 or more risers.
2. Top of the handrails shall be placed not less than 34 inches nor more than 38 inches above stair nosings.
3. The handgrip portion of handrails shall be not less than 1-1/4 inches nor more than 2 1/4 inches in cross section for non circular handrails.
4. Handrails shall be placed not less than 1-1/2 inches from any wall or other surface.
5. Handrails to be returned to wall, post or safety terminal (per 311.7.7.2 IRC)

Acceptable Handrail Details

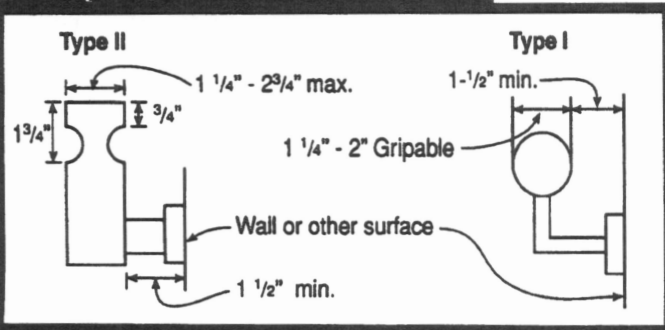

Unacceptable Handrails

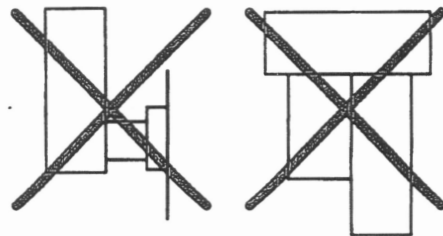

Fastener Spacing for Deck Ledger
(Deck Live Load = 40 psf, deck load = 10 sf)

Joist Span	6' and less	6'1" to 8'	8'1" to 10'	10'1" to 12"	12'1" to 14'	14'1" to 16"	16'1" to 18"
Connection Detail	On-Center Spacing of Fasteners (d,e)						
½" diameter lag screw with 15/32" max. sheathing	30	23	18	15	13	11	10
½" diameter bolt with 15/32" max. sheathing	36	36	34	29	24	21	19
½" diameter bolt with 15/32" max. sheathing & ½" stacked washers (b,h)	36	36	29	24	21	18	16

- a. The tip of the lag screw shall fully extend beyond the inside face of the band joist.
- b. The maximum gap between the face of the ledger board and the face of the wall sheathing shall be ½".
- c. Ledgers shall be flashed to prevent water from contacting the house band joist.
- d. Lag screws and bolts shall be staggered in accordance with Section R507.2.1.
- e. Deck ledger shall be minimum 2x8 pressure preservative treated No. 2 grade lumber or other approved materials as established by standard engineering.
- f. When solid-sawn pressure preservative treated deck ledgers are attached to a minimum 1" thick engineered wood product (structural composite lumber, laminated veneer lumber or wood structural panel band joist) the ledger attachment shall be designed in accordance with accepted engineered practices.
- g. A minimum 1"x9 ½" Douglas Fir laminated veneer lumber rimboard shall be permitted in lieu of the 2" nominal band joist.
- h. Wood structural panel sheathing or foam sheathing not exceeding 1" in thickness shall be permitted. The maximum distance between the face of the ledger board and the face of the band joist shall be 1".

Table R507.2.1
Placement of Lag Screws and Bolts in Deck Ledgers and Band Joists

Minimum End and Edge Distances and Spacing Between Rows				
	Top Edge	Bottom Edge	Ends	Row Spacing
Ledger(a)	2"(d)	¼"	2"(b)	1 5/8"(b)
Band Joist(c)	¾"	2"	2"(b)	1 5/8"(b)

- a. Lag screws or bolts shall be staggered from the top to the bottom along the horizontal run of the deck ledger in accordance with Figure R507.2(1)
- b. Maximum 5"
- c. For engineered rim joists, the manufacturer's recommendations shall govern.
- d. The minimum distance from the bottom row of lag screws or bolts to the top edge of the ledger shall be in accordance with Figure R507.2(1).

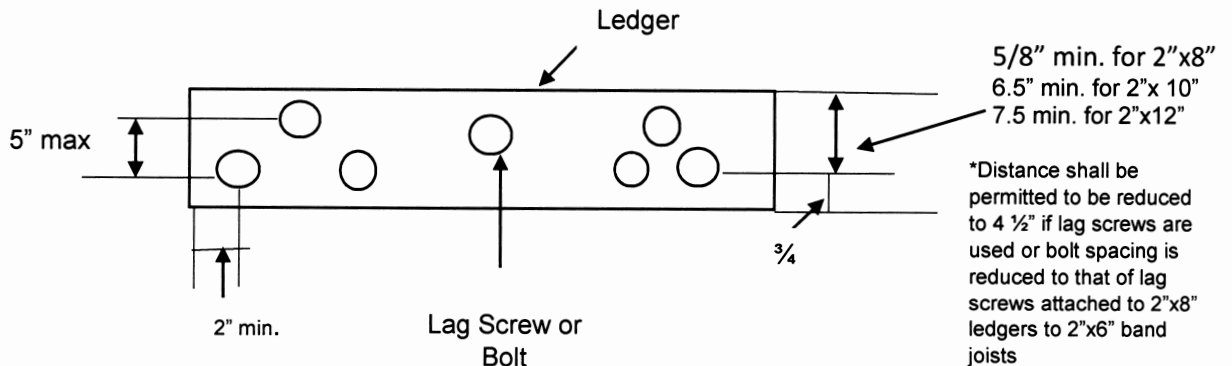

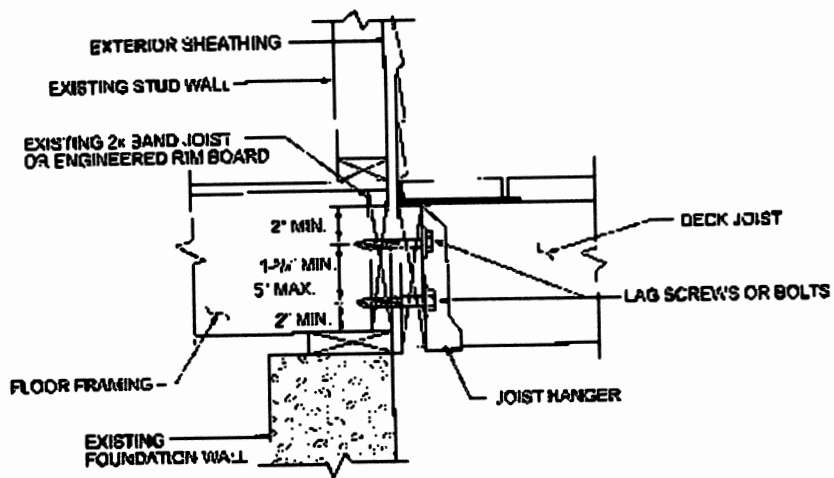

PLACEMENT OF LAG SCREWS AND BOLTS IN BAND JOISTS

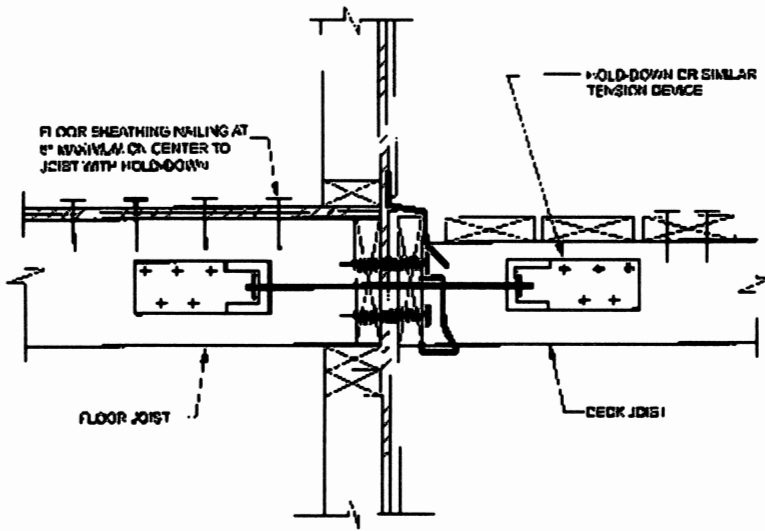

DECK ATTACHMENT FOR LATERAL LOADS

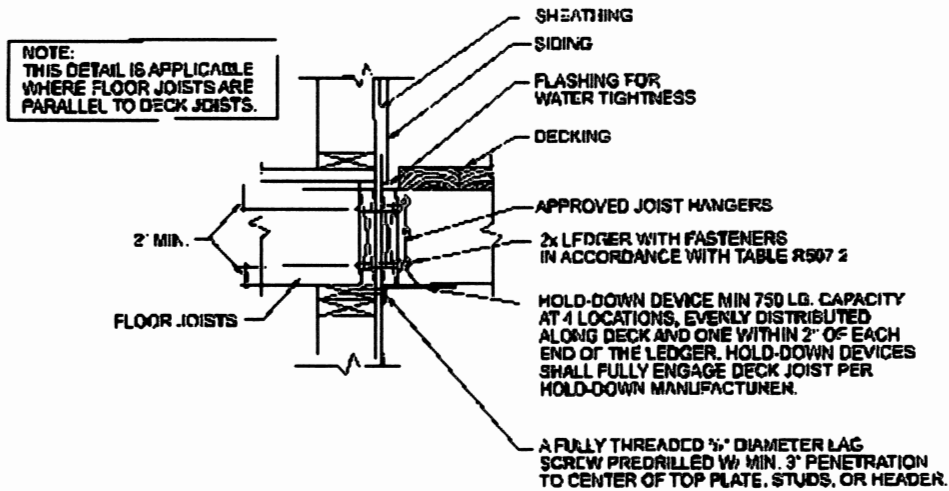

DECK ATTACHMENT FOR LATERAL LOADS

Maximum Joist Spacing

Material Type and Nominal Size	Maximum On-Center Joist Spacing	
	Perpendicular to joist	Diagonal to joist(a)
1 ¼" thick wood	16 inches	12 inches
2" thick wood	24 inches	16 inches

a. Maximum angle of 45 degrees from perpendicular for wood deck boards

Deck Joist Spans

	Size	Spacing of Deck Joists with No Cantilever			Spacing of Joist with Cantilevers		
		12"	16"	24"	12"	16"	24"
Douglas Fir #2	2x6	9-6	8-8	7-2	6-3	6-3	6-3

Cantilever spans not exceeding the nominal depth of the joist are permitted.

Deck Beam Span Lengths –Doug Fir #2

Size	Deck Joist Span Less than or Equal To:						
	6'	8'	10'	12'	14'	16'	18'
3x6 or 2-2x6	5-5	4-0	4-2	3-10	3-6	3-1	2-9
3X8 or 2-2X8	6-10	5-11	5-4	4-10	4-6	4-1	3-8
3X10 or 2-2x10	8-4	7-3	6-6	5-11	5-6	5-1	4-8
3x12 or 2-2x12	9-8	8-5	7-6	6-10	6-4	5-11	5-7
4x6	6-5	5-6	4-11	4-6	4-2	3-11	3-8
4x8	8-5	7-3	6-6	5-11	5-6	5-2	4-10
4x10	9-11	8-7	7-8	7-0	6-6	6-1	5-8
4x12	11-5	9-11	8-10	8-1	7-6	7-0	6-7
3-2x6	7-4	6-8	6-0	5-6	5-1	4-9	4-6
3-2x8	9-8	8-6	7-7	6-11	6-5	6-0	5-8
3-2x10	12-0	10-5	9-4	8-6	7-10	7-4	6-11
3-2x12	13-11	12-1	10-9	9-10	9-1	8-6	8-1

Deck Post Height

Measured to the Underside of the Beam

Deck Post Size	Maximum Height
4x4	8'
4x6	8'
6x6	14'

Decks with post higher than 14' shall be engineered by a State of Nevada design professional